



Total Food-Service Solutions

## Modular Cooking – Meritus 750

### Electric Pasta Cooker

#### NEPC 4-75 (D) MR

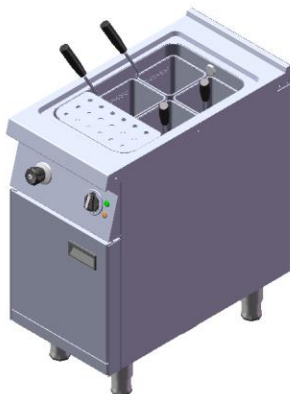

\*Due to routine technical improvement, the photograph shown may not represent the latest design of the products.

#### AVAILABLE MODEL

1. NEPC 4-75 (D) MR

#### DESCRIPTION

Electric Pasta Cooker with 7.2 kW power rate. Water temperature maintained by thermostat with maximum working temperature of 110°C. It is supported with bowls that can withstand to salt and acid and equipped with special noodle baskets supplied complete with the holder for easy handling. Unit to be installed on open cabinet or similar elements, cantilever, or solid block solutions. Featuring removable clip joint to connect Meritus family product.

ITEM# : \_\_\_\_\_

MODEL# : \_\_\_\_\_

NAME : \_\_\_\_\_

SN : \_\_\_\_\_

#### MAIN FEATURE

- Maximum working temperature of 110 C.
- Basin made of SS 316.
- Unit to be installed free standing, can be joined with base cabinet, table stand or cantilever system..
- Service maintenance can be done from the front panel.
- Water knob and faucet to refill water in the basin. included.

#### CONSTRUCTION

- All exterior panels in 304 type of Stainless Steel
- Orbital top panel anti-scratch finishing.
- Top and side are mounted by 1.5mm of Stainless Steel.
- Adjustable ±25 mm Stainless Steel leg.
- Certified IPX4 protection.

#### INCLUDED ACCESSORIES

- Basket Holder

#### OPTIONAL ACCESSORIES

- GN 1/4 Pasta Basket (4).
- Clip Plate for Joining.



\_\_\_\_\_

The company reserves the right to make modifications to the products without prior notice. All information correct at time of printing.  
2018.12.04



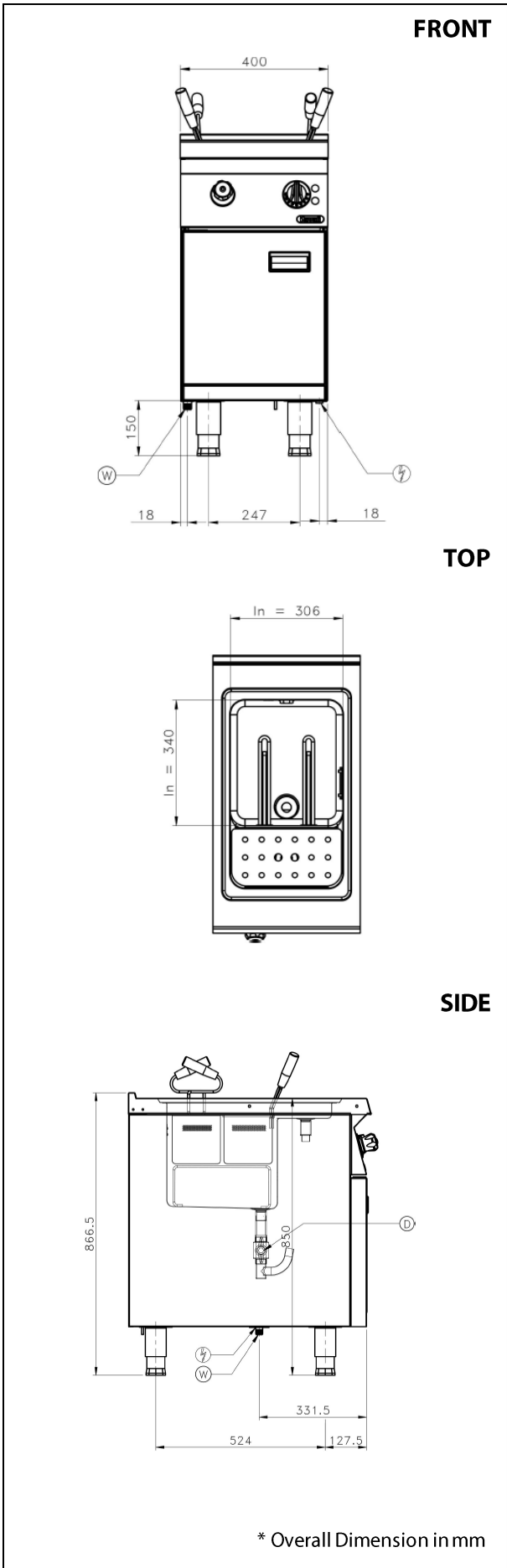

**ELECTRIC**

Electrical rating (kW)	:	7.2
Element rating (kW)	:	7.2
Electrical supply voltage	:	400V 3N
Required electrical supply (amps):		16

**KEY INFORMATION**

Unit dimension (WxDxH)	:	400x750x850/866 mm
Cooking surface (WxD)	:	306 x 340 mm
Direct heat emission	:	0.25 kW
Latent heat emission	:	1.40 kW
Steam emission	:	2.10 kg / h
Working temperature	:	30°-110°C
Number of heaters	:	2
Water inlet connection	:	½"
Water outlet connection	:	1"
Tank capacity	:	28 Liters
Net weight	:	47 kg

**PACKING DETAILS**

Shipping width	:	470 mm
Shipping depth	:	850 mm
Shipping height	:	1060 mm
Shipping volume	:	0.423 m³
Gross weight	:	60 kg